

NYS 3-8 ELA and Math CBT Field Test Proctor/Teacher Training



New York State
EDUCATION DEPARTMENT

Knowledge > Skill > Opportunity



Agenda

- Overview
- Logging in to Nextera
- Finding your class lists and students
- Preparing for test day
 - Student log in credentials
 - Session pins/Access Codes
 - Proctor password
- On test day
- Proctoring the computer-based field test

3-8 ELA & Math Computer-Based Field Test

- CBT Field Test Window: May 23 – June 10, 2016
- Schools were selected for one grade and either ELA or math
- Multiple-choice and short- and extended-response
- Single class period of approximately 40 minutes
- Teacher Directions available online at <http://www.p12.nysed.gov/assessment/fieldtest/>

Nextera System Overview

Nextera is made up of two components:

- Nextera Admin -- Test Administration System
 - Student and testing management tools
- Test Delivery System (Secure Browser)
 - Secure browser keeps students focused on their test

The background is a solid blue color with several thin, white, curved lines that intersect to form abstract geometric shapes, possibly representing a network or a stylized globe.

Nextera Online Administration System

Logging in to Nextera Administration

To access Nextera Admin you can either:

1. Contact the District Test Coordinator (DTC) or School Test Coordinator (STC) in your district or school and ask them to reset your password in Nextera;

OR

2. Click **Create an Account** on the login page and fill in the fields and click submit.



New York State Grades 3-8 Testing Program
Powered by Nextera™

User ID

Password

Forgot your password?
First Time User? [Create an Account](#)

© 2016 Questar Assessment, Inc.
Nextera is a registered trademark of Questar Assessment, Inc.
[Privacy and Terms](#)

Home Screen

Spring 2015-16 | Training Test District (0000001) | Test Middle School (0000001-1) | No Conte... [Change](#)

Teacher Three [Sign out](#)

New York State Grades 3-8 Testing Program



[HOME](#) [STUDENTS](#) [CLASSES](#) [TESTS](#) [ACCOUNTS](#) [HELP](#)

Your Profile

Name: Teacher Three
Email: ctooker@questarai.com
Associated with: Test Middle School (0000001-1)

Administration Quick Links

Teacher Checklist

Please find the help information below.

What's New

Please find the help information below.

Student and Class Information

Classes

- Classes, in Nextera, refer to students grouped for testing purposes.
- Classes are assigned to a teacher by the DTC or STC. A teacher may have multiple classes. Classes may or may not have a proctor indicated.
- Classes are connected to the teacher who is administering the field test (not necessarily the teacher of record).
- A student **must** be assigned to a class to participate in the field test.

View Students

1. Select **Students** from the **Students** tab.
2. Select **View**.

*To download the class list, select the **Download Class List (Excel)** link in the lower, right corner of the screen.

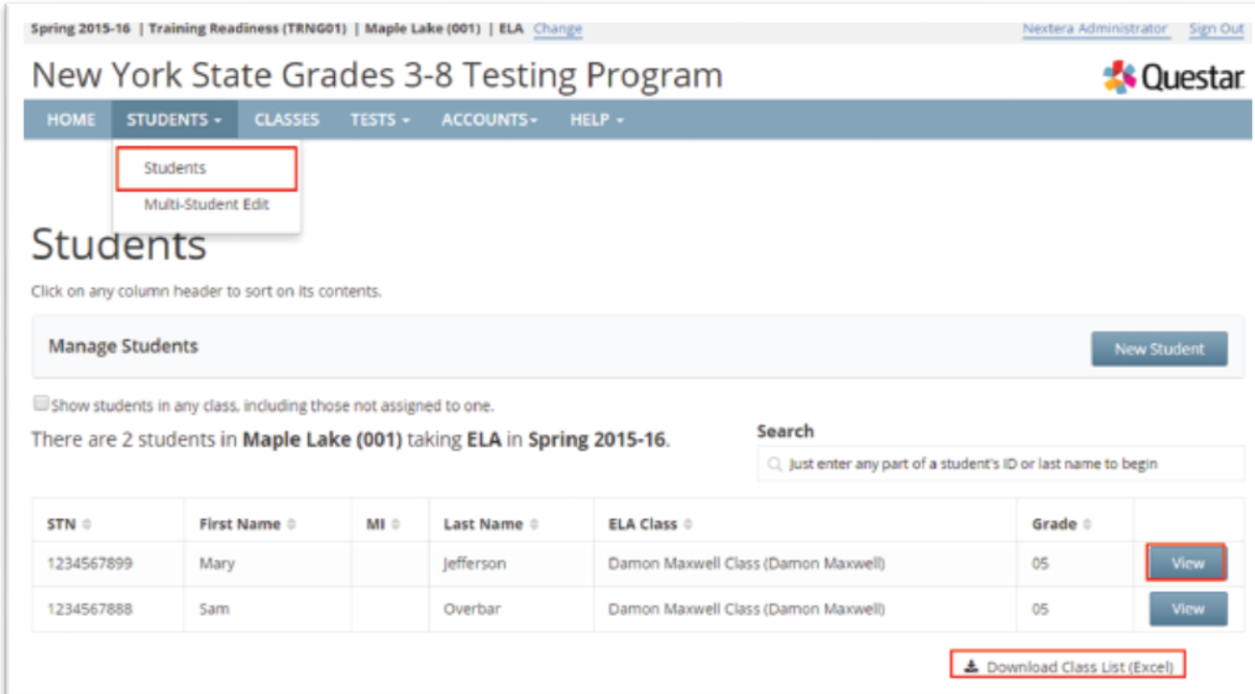

The screenshot shows the Questar interface for the New York State Grades 3-8 Testing Program. The 'STUDENTS' tab is selected, and a dropdown menu is open, highlighting 'Students'. Below the navigation bar, the 'Students' section is visible, including a 'Manage Students' button and a 'New Student' button. A search bar is present with the text 'just enter any part of a student's ID or last name to begin'. A table lists two students, and the 'View' button for the first student is highlighted. At the bottom right, there is a 'Download Class List (Excel)' link.

Spring 2015-16 | Training Readiness (TRNG01) | Maple Lake (001) | ELA [Change](#) Nextera Administrator [Sign Out](#)

New York State Grades 3-8 Testing Program

HOME STUDENTS - CLASSES TESTS - ACCOUNTS - HELP -

Students
Multi-Student Edit

Students

Click on any column header to sort on its contents.

Manage Students New Student

Show students in any class, including those not assigned to one.

There are 2 students in **Maple Lake (001)** taking **ELA** in **Spring 2015-16**.

Search

STN	First Name	MI	Last Name	ELA Class	Grade	
1234567899	Mary		Jefferson	Damon Maxwell Class (Damon Maxwell)	05	View
1234567888	Sam		Overbar	Damon Maxwell Class (Damon Maxwell)	05	View

[Download Class List \(Excel\)](#)

View Students

3. To view the details of a particular student, select **View** for the applicable student. Information displayed includes the student's name, grade, date of birth, class name, accessibility and accommodation options, etc.
4. To return to the Class List, select **Back to students list** in the upper left corner of the screen.

⊖ Back to students list

View Student

You're Viewing: **Test Student**

District of Record: Training Test District (0000001) School of Record: Test Middle School (0000001-1)

Demographic Information:

STN	012345	Grade	Grade 3
First Name	Test	MI	
Date of Birth	01/01/2010	Last Name	Student
		Gender	Female

View a Class

1. Select the **Classes** tab.
2. To see details regarding a class, select **View**.

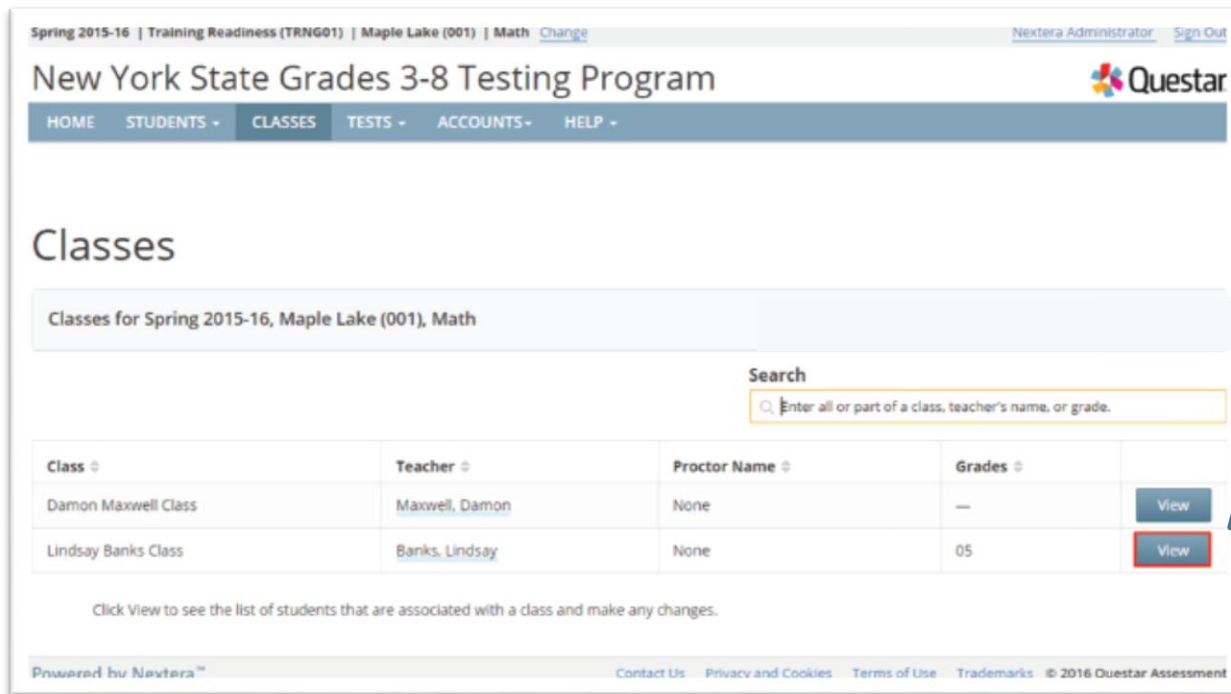

The screenshot shows the Questar interface for the New York State Grades 3-8 Testing Program. The user is logged in as 'Nextera Administrator'. The 'CLASSES' tab is selected in the navigation menu. The page title is 'Classes' and the subtitle is 'Classes for Spring 2015-16, Maple Lake (001), Math'. A search bar is present with the placeholder text 'Enter all or part of a class, teacher's name, or grade.' Below the search bar is a table with the following data:

Class	Teacher	Proctor Name	Grades	
Damon Maxwell Class	Maxwell, Damon	None	—	View
Lindsay Banks Class	Banks, Lindsay	None	05	View

A blue arrow points to the 'View' button for the 'Lindsay Banks Class'.

Click View to see the list of students that are associated with a class and make any changes.

Powered by Nextera™ [Contact Us](#) [Privacy and Cookies](#) [Terms of Use](#) [Trademarks](#) © 2016 Questar Assessment

Preparing for Test Day

The background is a solid blue color. Overlaid on this are several thin, light blue lines that intersect to form various geometric shapes, including triangles and quadrilaterals. The lines are thin and have a slight transparency, creating a subtle pattern behind the text.

Preparing for Test Day

- Student login credentials
- Session pin (Access code)
- Proctor password

Login Credentials (Labels)

Each student will need Login Credentials to log in to the test session.

View Test

You're Viewing: **English II**

District:	Alpha Practice (353-535)	School:	Alpha High School (1002)
Testing Window:	Fall 2015-16	Content Area:	English II
Test Administrator:	Nasir Khan	Class:	ELA 1
Test Name:	English II		
Testing Dates:	11/30/2015 to 12/11/2015		

Examiner View

Print Labels

English II PIN 6228

New PIN

Submit

Cancel

Last Name	First Name	User ID	Password	Status	Total Items Completed	Date/Time Started	Date/Time Completed	Status Codes
Andretti	Shayna	557636542	F4A21348	English II: Not Started	0			Set
Haskell	Olivia	422554212	AEEFE524	English II: Not Started	0			Set
Jenkins	Alphonse	987335466	FC260310	English II: Not Started	0			Set
Kasperian	Bernard	982367415	E4391529	English II: Not Started	0			Set

Login Credentials (Labels)

1. Select **Tests** from the **Tests** tab.
2. Select **View** for the applicable test.
3. Select **Print Labels**.
4. Select the **applicable form** (Avery labels or student roster).
5. Select **OK**.
6. The labels display. Use the **Print** function to print the labels. Each label includes a student's name, test name, user ID, and password.

Access Code

The Session PIN is the **Access Code** the teacher will provide to the students during the administration of the field test.

View Test

You're Viewing: **English II**

District:	Alpha Practice (353-535)	School:	Alpha High School (1002)
Testing Window:	Fall 2015-16	Content Area:	English II
Test Administrator:	Nasir Khan	Class:	ELA 1
Test Name:	English II		
Testing Dates:	11/30/2015 to 12/11/2015		

Examiner View

Print Labels

English II PIN 6228

New PIN

Submit

Cancel

Last Name	First Name	User ID	Password	Status	Total Items Completed	Date/Time Started	Date/Time Completed	Status Codes
Andretti	Shayna	557636542	F4A21348	English II: Not Started	0			Set
Haskell	Olivia	422554212	AEEFE524	English II: Not Started	0			Set
Jenkins	Alphonse	987335466	FC260310	English II: Not Started	0			Set
Kasperian	Bernard	982367415	E4391529	English II: Not Started	0			Set

Proctor Password

- The proctor password is needed any time a student pauses (exits out of) the test. See Appendix C of the Teacher's Directions.
- Teachers need to contact DTC or STC to obtain the proctor password. It is located on the DTC/STC's **home screen**.
- Each school has a unique proctor password.

Schools:
School: Test Middle School (0000001-1)
School Test Coordinator: STC Middle
Proctor Password: LWZG564V
School: Test Elementary School (0000001-2)
School Test Coordinator: STC Elem
Proctor Password: VB2Y7WFB

The background is a solid blue color. Overlaid on this are several thin, white, curved lines that intersect to form a series of irregular, overlapping shapes, resembling a stylized map or a network diagram. The lines are thin and white, creating a subtle geometric pattern.

On Test Day

Teacher's Directions

- Become familiar with the Teacher's Directions for computer-based field testing, located at <http://www.p12.nysed.gov/assessment/fieldtest/>:
 - [Grades 3-5 Math Teacher's Directions](#)
 - [Grades 6-8 Math Teacher's Directions](#)
 - [Grades 3-5 ELA Teacher's Directions](#)
 - [Grades 6-8 ELA Teacher's Directions](#)

Preparing Your Exam Room

- Provide a well-lit, well-ventilated, and quiet classroom.
- Ensure all devices have been set up with the Questar Secure Browser. Direct any questions to your school's technical support.
- Plan seating arrangements. Allow enough space between students to prevent sharing of answers.
 - A seating chart or other record of student device assignment is recommended in the event that a situation requires a student to leave and return to a device.
- See the Teacher's Directions for more information on space set-up.

Materials for Testing

1. Teacher's Directions
2. Student device setup:
 - Devices are powered on and connected to a power source if necessary
3. Provide students with login credentials
4. Proctor device with internet access to monitor testing (not required)
5. Access Code (Session PIN)
6. Proctor Password (obtain from DTC/STC)
7. Additional supplies*

*See the Teacher's Directions for complete list of required materials.

Proctoring the Computer-Based Field Test

The background is a solid blue color. Overlaid on this are several thin, light blue lines that intersect to form various geometric shapes, including triangles and quadrilaterals. These lines are positioned primarily on the right side of the slide, creating a modern, abstract design.

Proctoring the CBT Field Test

- Before testing, be aware of the accommodations available in the Nextera test delivery system and whether or not these have been identified as appropriate for any of your students with IEPs or 504 Plans.
 - If a student should have received one of the online accommodations such as reverse contrast, and that modification does not appear, pause testing for that student and contact your School Test Coordinator immediately.
- Active proctoring is expected. Circulate the room during testing.

Examiner View

- To monitor student testing while proctoring the exam
- Must have a device connected to the internet in order to use the Examiner View
- Information included on this page:
 - Student's name
 - User ID; Password
 - Test Status
 - Total Items Completed
 - Date/Time Started
 - Date/Time Completed

Proctoring the CBT Field Test

- May support students in the mechanics of taking the test
 - Become familiar with the tools through the Question Sampler, available at <https://ny-practice.nextera.questarai.com>
 - Note: Access the Question Sampler with Google Chrome Browser

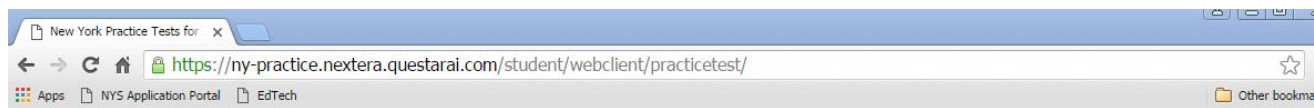

New York State Grades 3-8 Testing Program Question Sampler

The New York State Education Department and Questar are committed to supporting students, families, teachers and administrators through every step of the testing process. The Question Sampler offers an opportunity for students to become familiar with the test format, the question types and the tools they will experience during testing.

[Learn more](#) or try the Question Samplers below.

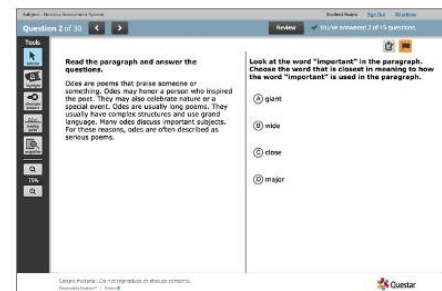

Tools

- The tools appear on the left side
- Blue tool = Active
- Selector = Select answer

The screenshot displays a math assessment interface for "Math - Grade 4". At the top, it indicates "Question 4 of 8" and "You've answered 0 of 8 questions." A "Review" button is visible. On the left, a "Tools" sidebar is active, showing icons for ruler, protractor, selector (highlighted in blue), highlight, and eliminate answers. The main question asks "Which angle measures 25° ?" and shows four diagrams labeled (A), (B), (C), and (D). Each diagram consists of a horizontal ray pointing right and another ray pointing up or down from the same vertex. Diagram (A) has a small acute angle, (B) has a larger acute angle, (C) has a small obtuse angle, and (D) has a larger obtuse angle. At the bottom, there is a disclaimer: "Don't share or discuss the contents of this test or material with others." and the Questar logo.

Tools: Ruler and Protractor

- Move: Click and Drag
- Spin: Gray circle with Curved double-arrow line
- Exit: Red Circle

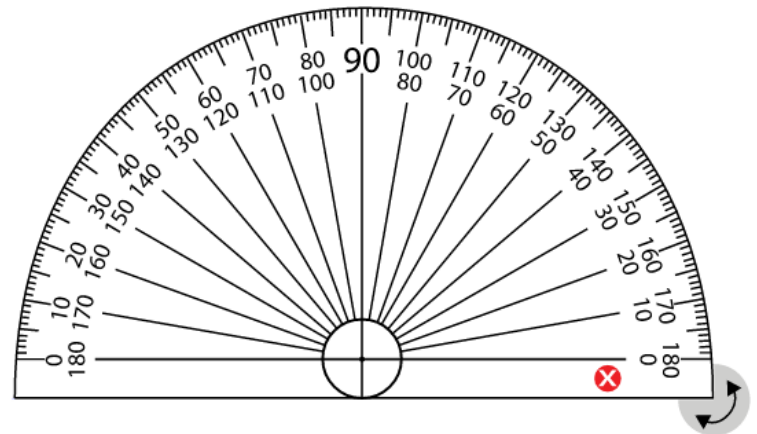
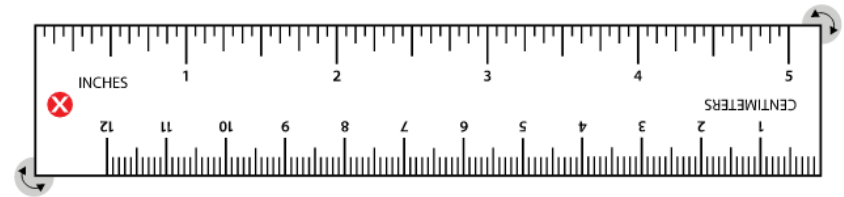

Tools: Highlighter

- Highlighter icon is Yellow = Highlight
- Highlighter icon is White = Erase Highlighting

Review

Question 1 of 7
✓ You've answered 0 of 7 questions.

Tools

selector

highlight

eliminate answers

100%

Jason's Gold

by Will Hobbs

When the story broke on the streets of New York, it took off like a wildfire on a windy day.

"Gold!" Jason shouted at the top of his lungs. "Read all about it! Gold discovered in Alaska!"

5 The sturdy fifteen-year-old newsboy waving the paper in front of Grand Central Depot had arrived in New York only five days before, after nearly a year spent working his way across the continent.

Tools: Passage Expander and Scroll Bars

- Resize reading area

- Scroll

ELA - Grade 8

Question 1 of 7
You've answered 0 of 7 questions.

Review

Tools

- selector
- highlight
- eliminate answers

Jason's Gold

by Will Hobbs

Read the sentence from line 12 of the passage.

People were running toward him like iron filings to a magnet.

The author uses this simile to emphasize that the people

- (A) were interested in the news about the gold
- (B) were curious about the ship's arrival
- (C) wanted to become gold prospectors
- (D) were unable to resist reading about the gold

Don't share or discuss the contents of this test or material with others.

Powered by Nextera™ | Version 8.0.0 | 1/1/2016

Questar

Other Tools

- Answer Eliminator
- Calculator
- Reading Guide

The screenshot shows a digital reading interface. On the left, a vertical toolbar contains three icons: a mouse cursor labeled 'selector', a highlighter labeled 'highlight', and a crossed-out 'a' labeled 'eliminate answers'. The main content area displays a passage titled 'Jason's Gold' by Will Hobbs. The text includes: 'When the day. "Gold!" Alaska!"' and '5 The student Depot had way across "Gold sl Prospecto'. A question asks to read the sentence from line 12: 'People were running toward him like iron filings to a magnet.' The author's purpose is to emphasize that the people: (A) were interested in the news about the gold, (B) were curious about the ship's arrival, (C) ~~wanted to become gold prospectors~~, and (D) ~~were unable to resist reading about the gold~~. The incorrect options C and D are crossed out with red lines.

Proctoring the CBT Field Test

- May assist students on the **Review** screen before student submits the test

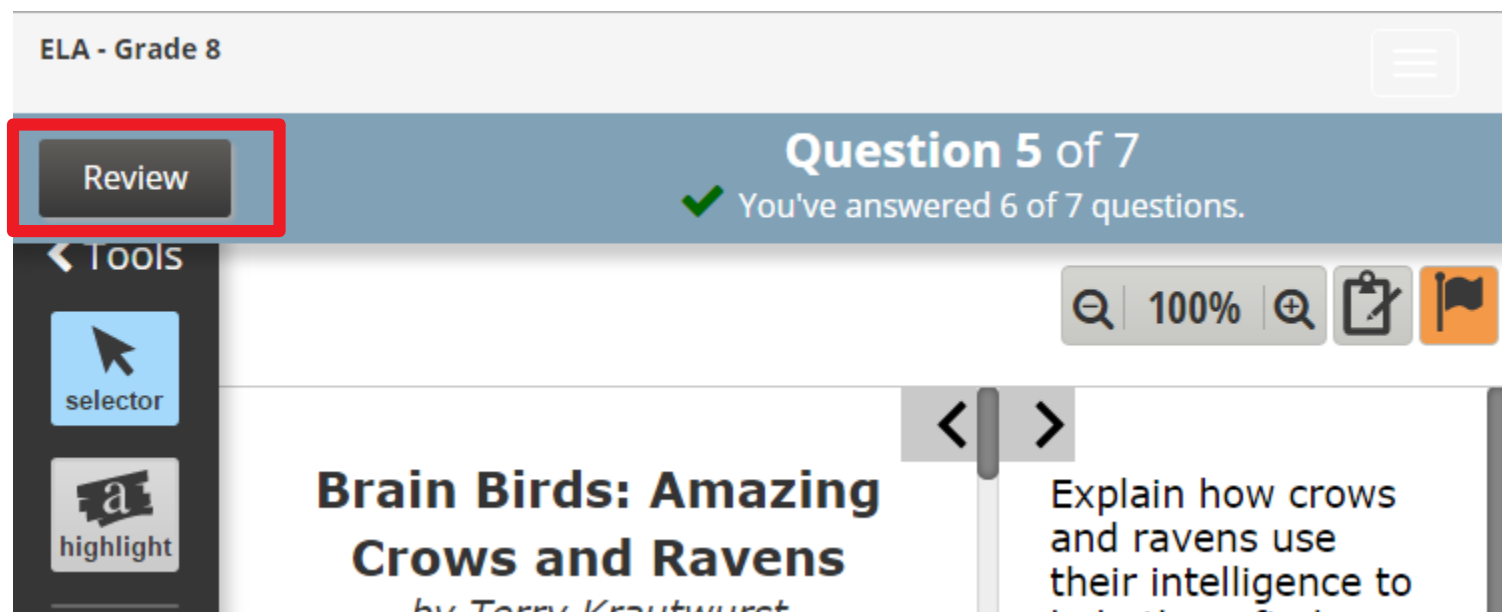

The screenshot displays the CBT Field Test interface for ELA - Grade 8. The top navigation bar shows "ELA - Grade 8" and a menu icon. Below this, a blue header bar contains the text "Question 5 of 7" and a green checkmark with the message "You've answered 6 of 7 questions." A red box highlights the "Review" button in the top left corner. To the right of the "Review" button is a "TOOLS" menu with icons for "selector" and "highlight". Further right are icons for search, zoom (100%), clipboard, and flag. The main content area shows the title "Brain Birds: Amazing Crows and Ravens" by Terry Krautwurst, with a question prompt: "Explain how crows and ravens use their intelligence to..."

Proctoring the CBT Field Test

- May assist students on the **Review** screen before student submits the test

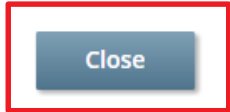

Review your test

Question #	Answered	Flags	Notes
1	Yes		
2	Yes		
3	Yes		
4	Yes		
5	Yes		
6	Yes		
7	No		

You have **answered 6 of 7** questions.

Click or tap the I'm Done button when you have finished your test.

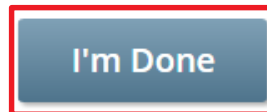

Technical Issues During Administration

- In the first year of implementation of a large-scale computer-based field test, there is a possibility that some schools will encounter technology issues.
- We want to reassure you that these field tests have no stakes for students, teachers, or schools.
- If you need technical assistance during the field test, please use your local technical supports or contact Questar Customer Support at 866-997-0695 Monday-Friday 7:30 a.m. to 4:30 p.m. (ET) or NY.3-8.help@questarai.com.

Contact Questar

New York State Grades 3-8 Testing Program



HOME STUDENTS CLASSES TESTS ▾ ACCOUNTS ▾ HELP ▾

Help

Contact Support



Call

[866.997.0695](tel:866.997.0695)



Email

[click here](#)



Chat

[Chat Now](#)

Contact Information

Questar New York Customer Support

NY.3-8.help@questarai.com

866-997-0695

Thank you!



Questar™

